



# Maintenance Guide

## Insert-A-Shaft® 10EFM 1:1 Right Angle Gearbox

### Foot Mount Models

A/B Bores: .500, .625 | Group C

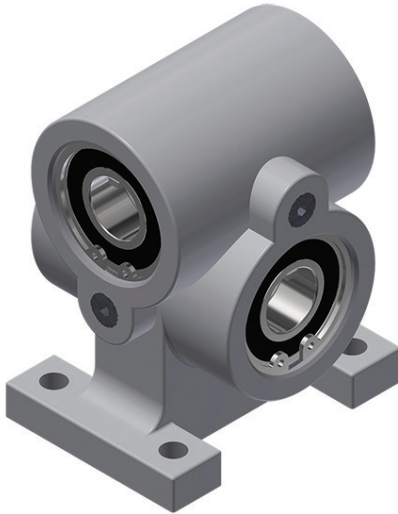

Prod. #	Model
4301-0104	IAS10EFM1:1RHA.500B.625
4301-0105	IAS10EFM1:1LHA.500B.625

### Shaft Requirements

- Diameter tolerance should be  $+.000/-0.002$  in. For traversing applications it is recommended to be  $.001/.002$  in. under nominal.
- Runout should be within  $.002$  in.
- Straightness should be within  $.002$  in. TIR. Per foot.
- Material should be suitable for the particular application. Carbon, alloy or stainless steel shafting may be used.
- Shaft finish should be 64 RMS or better for stationary applications and 32 RMS or better for traversing applications.
- Keyway should be made  $0.001/0.002$  in. over nominal Edges should be de-burred.

### Shaft Support

Shafting should be supported on all sides of gearbox with external bearing blocks. The internal gearbox bearings are designed to handle the internal loads and are not suitable to support additional, external radial or thrust loads. Failure to support external loads will reduce the gearbox efficiency and service life.



### Lubrication

#### CAUTION: DO NOT FILL GEARBOX WITH GREASE!

Insert-A-Shaft gearboxes are pre-lubricated and ready for service. For light and moderate duty applications they may be considered lubed for life and no further service is required.

For continuous and severe duty use, periodic maintenance may be required. It is recommended to purge grease and re-lubricate every 1,500 hrs of service.

For standard IAS models, lubricate with Magnalube-G® NLGI Grade 2 grease. For Food Grade application, use ACCROLUBE®-FG grease.

For CRL models, lubricate with Lubriplate® 1500 Grade 00 grease. For Food Grade applications use Lubriplate®, FGL-00 grease.

When lubricating remove the lower most port plug and inject new grease into zerk fitting in upper most port purging old grease out lower port. Re-install port plug.

Lubrication amounts:  
22/25 series = 1 oz (30ml), 20 series = .67 oz (20ml),  
15 and 10 series = .50 oz (15ml)

**Note: Overfilling may result in leakage, excessive heat and reduced service life.**



**IAS10EFM Group C Lubricant (3-oz.):**

#4300-9102, Magnalube-G All Standard Non-FG, Non-CRL Models  
 #4300-9103\*, Accrolube-FG Food Grade #2 For Non-CRL Food Grade  
 \*Optional

**Available Repair Kits:**

- \* 4301-9006 Kit: Seals / Spacers
- \*! 4301-9007 Kit: Seals / Spacers / LH Gears / Bearings
- \*! 4301-9008 Kit: Seals / Spacers / RH Gears / Bearings

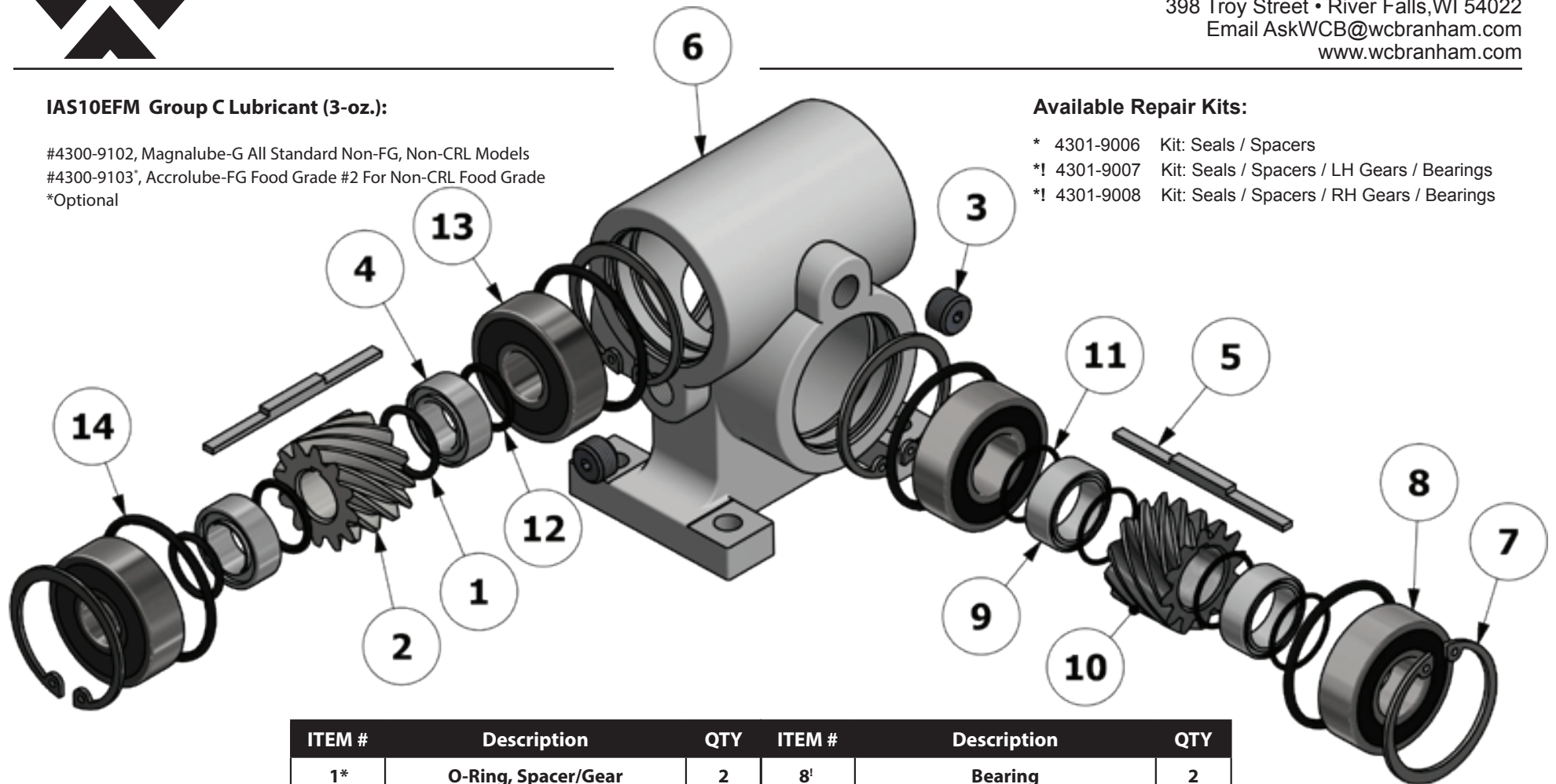

ITEM #	Description	QTY	ITEM #	Description	QTY
1*	O-Ring, Spacer/Gear	2	8 <sup>!</sup>	Bearing	2
2 <sup>!</sup>	Gear	1	9*	Spacer	2
3	Plug	2	10 <sup>!</sup>	Gear	1
4*	Spacer	2	11*	O-Ring, Spacer	4
5	Key	2	12*	O-Ring, Spacer/Bearing	2
6	Housing	1	13 <sup>!</sup>	Bearing	2
7	Ring, Retaining	4	14*	O-Ring, Bearing/Housing	4