

# Cable Cylinders

**Models: I200/I203; I201/I206; I250/I251; I300/I301; I400/I401**

Assembly No. \_\_\_\_\_

Serial No. \_\_\_\_\_

Stroke \_\_\_\_\_

Cut Cable (A) \_\_\_\_\_

Cut Cable (B) \_\_\_\_\_

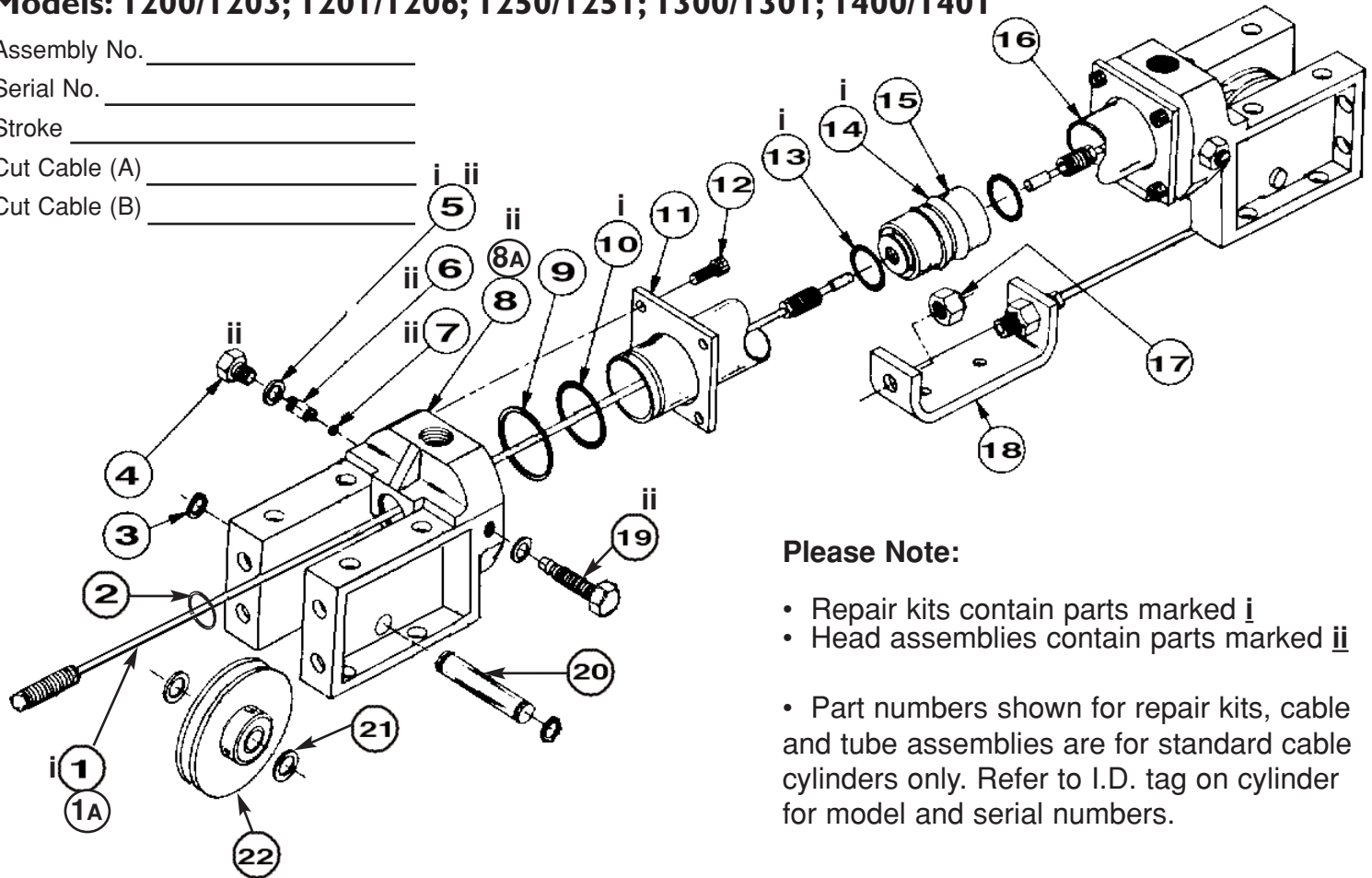

**Please Note:**

- Repair kits contain parts marked **i**
- Head assemblies contain parts marked **ii**
- Part numbers shown for repair kits, cable and tube assemblies are for standard cable cylinders only. Refer to I.D. tag on cylinder for model and serial numbers.

ITEM	MODEL NO.	PART NO.	DESCRIPTION	QTY
I	I200/I203	I200-9033	CABLE ASSY (SK)	2
I	I201/I206	I300-9100	CABLE ASSY (SK)	2
I	I250/I251	I250-9033	CABLE ASSY (SK)	2
I	I300/I301	I300-9100	CABLE ASSY (SK)	2
I	I400/I401	I400-9100	CABLE ASSY (SK)	2
IA	I200/I203	I200-9034	REPAIR KIT (SK)	1
IA	I201/I206	I201-9101	REPAIR KIT (SK)	1
IA	I250/I251	I250-9018	REPAIR KIT (SK)	1
IA	I300/I301	I300-9101	REPAIR KIT (SK)	1
IA	I400/I401	I400-9101	REPAIR KIT (SK)	1
2	ALL	I200-1031	RETAINING RING	2
3	ALL	I150-1031	RETAINING RING	4
4	I200/I203	I150-1036	SCREW, BALL CHECK	2
4	I201/I206	I200-1029	SCREW, BALL CHECK	2
4	I250/I251	I150-1036	SCREW, BALL CHECK	2
4	I300/I301	I200-1029	SCREW, BALL CHECK	2
4	I400/I401	I200-1029	SCREW, BALL CHECK	2
5	ALL	I150-1065	THREAD SEAL	4
6	ALL	I200-1028	SPRING, BALL CHECK	2
7	ALL	I150-1026	BALL, CHECK	2
8	I200/I203	I200-9009	HEAD ASSEMBLY	2
8	I201/I206	I300-9003	HEAD ASSEMBLY	2
8	I250/I251	I250-9006	HEAD ASSEMBLY	2
8	I300/I301	I300-9003	HEAD ASSEMBLY	2
8	I400/I401	I300-9003	HEAD ASSEMBLY	2

ITEM	MODEL NO.	PART NO.	DESCRIPTION	QTY
8A	I200/I203	I204-4003	HEAD ONLY	2
8A	I201/I206	I304-4000	HEAD ONLY	2
8A	I250/I251	N/A	ORDER HEAD ASSEMBLY	2
8A	I300/I301	I304-4000	HEAD ONLY	2
8A	I400/I401	I304-4000	HEAD ONLY	2
9	I200/I203	I200-1030	RETAINING RING, TUBE	2
9	I201/I206	I200-1030	RETAINING RING, TUBE	2
9	I250/I251	I250-1006	RETAINING RING, TUBE	2
9	I300/I301	I300-1018	RETAINING RING, TUBE	2
9	I400/I401	I400-1004	RETAINING RING, TUBE	2
10	I200/I203	I200-1010	O-RING, BUNA-N	2
10	I201/I206	I200-1010	O-RING, BUNA-N	2
10	I250/I251	I880-1063	O-RING, BUNA-N	2
10	I300/I301	I300-1005	O-RING, BUNA-N	2
10	I400/I401	I400-1000	O-RING, BUNA-N	2
11	I200/I203	I200-1022	PLATE, CLAMP	2
11	I201/I206	I200-1035	PLATE, CLAMP	2
11	I250/I251	I250-1005	PLATE, CLAMP	2
11	I300/I301	I300-1020	PLATE, CLAMP	2
11	I400/I401	I400-1005	PLATE, CLAMP	2
12	ALL	I200-1041	SHCS, 5/16-18 x 1 1/4	8
13	ALL	I200-1002	O-RING, BUNA-N	2
14	I200/I203	I200-1009	U-CUP, BUNA-N	2
14	I201/I206	I200-1009	U-CUP, BUNA-N	2
14	I250/I251	I250-1000	U-CUP, BUNA-N	2
14	I300/I301	I300-1001	U-CUP, BUNA-N	2

(SK) = SPECIFY STROKE LENGTH, INCHES.

## PARTS LISTING (CONT'D)

ITEM	MODEL NO.	PART NO.	DESCRIPTION	QTY
14	1400/1401	1400-1002	U-CUR, BUNA-N	2
15	1200/1203	1200-4-1018	PISTON	1
15	1201/1206	1200-1036	PISTON	1
15	1250/1251	1250-4-1004	PISTON	1
15	1300/1301	1300-4-1042	PISTON	1
15	1400/1401	1404-4000	PISTON	1
16	1200	1200-9074	TUBE ASSY (SK) STEEL	1
16	1203	1200-9082	TUBE ASSY (SK) ALUM.	1
16	1201	1201-9114	TUBE ASSY (SK) STEEL	1
16	1206	1201-9113	TUBE ASSY (SK) ALUM.	1
16	1250	1250-9051	TUBE ASSY (SK) STEEL	1
16	1251	1250-9074	TUBE ASSY (SK) ALUM.	1
16	1300	1300-9119	TUBE ASSY (SK) STEEL	1
16	1301	1300-9016	TUBE ASSY (SK) ALUM.	1
16	1400	1400-9144	TUBE ASSY (SK) STEEL	1
16	1401	1400-9145	TUBE ASSY (SK) ALUM.	1
17	ALL	4000-1108	NUT, NYLOC 5/8-18	2
18	1200/1203	1200-1021	BRACKET, CLEVIS	1
18	1201/1206	1303-4000	BRACKET, CLEVIS	1
18	1250/1251	1200-1021	BRACKET, CLEVIS	1
18	1300/1301	1303-4000	BRACKET, CLEVIS	1
18	1400/1401	1303-4000	BRACKET, CLEVIS	1
19	ALL	1150-4-1033	NEEDLE, CUSHION	2
20	ALL	1200-4-1019	PIN, SHEAVE	2
21	ALL	1150-4-1063	SPACER, SHEAVE	8
22	1200/1203	1200-9010	SHEAVE/BRG ASSY	2
22	1201/1206	1300-9005	SHEAVE/BRG ASSY	2
22	1250/1251	1200-9010	SHEAVE/BRG ASSY	2
22	1300/1301	1300-9005	SHEAVE/BRG ASSY	2
22	1400/1401	1300-9005	SHEAVE/BRG ASSY	2

### INSTALLATION TIPS

- When installing your W.C. Branham cable cylinder be extra careful not to scratch or mar the nylon jacket on the cable. If minor damage does occur it may be removed by buffing the marred area with a very light grade of emery paper. If damage is deep it is best to order a replacement cable assembly. Locate the repair kit part number on previous page.
- The cable cylinder may be mounted from either the top or bottom surface of the cylinder heads. When attaching the clevis or load bracket to the item to be driven be sure it is in perfect alignment to the center line of the cylinder in order not to deflect the cable to either side. Such deflection will cause premature cable fatigue and seal failure.
- All cable cylinders are shipped without the cables being pretensioned. The cables must be tensioned after mounting to insure the maximum service life of the cylinder. See pretensioning instructions to the right.

### PREVENTIVE MAINTENANCE

Your cable cylinder should be part of a preventive maintenance program. Most likely, the cable cylinder is being used in a high production area where downtime is crucial. It is suggested that you order a repair kit for the cable cylinder and place it in your stores area. By doing so, you minimize the downtime should any unforeseen emergency result.

We suggest that the cable cylinder be kept as clean as possible. Periodically inspect the sheaves, cable and gland seals for contaminants.

Adequately lubricate the cable cylinder with SAE 10 or 20 non-detergent oil.

©1999 W.C. Branham Inc. All Rights Reserved

## PRETENSIONING INSTRUCTIONS

There are two types of inherent stretch in cable - constructional and elastic. The constructional stretch is removed by proof loading the cable. The elastic stretch is removed by proper pretensioning the cable.

### -PROOF LOADING THE CABLES-

- Tighten the clevis terminal lock nuts equally with a torque wrench to the specified torque value in Table 1.
- Let set for 30 seconds to one minute.
- Loosen lock nuts to remove tension, but tight enough to eliminate any slack.
- Proceed with pretensioning instructions.

### PRETENSIONING-

- Block the driven member some distance from the end of travel to keep the cylinder piston from bottoming into the cylinder head. *If the driven member cannot be blocked for cable pretensioning, use the alternate method described on next page.*

**TABLE 1. TORQUE REQUIRED TO PROOF LOAD CABLES**

Bore Size	Torque, in.lb
0.5"	15
.75"	15
1.0"	15
1.5"	45
1.75"	45
2.0"	115
2.5"	115
3.0"	210
4.0"	210
2.0"HP	210

- Apply pressure to the cylinder that is 15% to 20% higher than actual load pressure. Load pressure is defined as the pressure required to move the driven member. *Note: If the driven member is stopped externally before the cylinder piston bottoms out during operation, the relief valve or regulator setting becomes the load pressure.*
- Upon pressurizing the cylinder you will notice one cable become slack and the other will become tight. Manually adjust out the slack by tightening the terminal lock nut.
- Release the pressure.

- Block the driven member from the opposite side. Pressurize the other cylinder port. Repeat the manual adjustment procedure on the other cable, step 3.

- Release the pressure and remove the block from the driven member.

- The cable is now pretensioned. Additional manual adjustment should not be required. It is suggested, however, that the cable be checked periodically and be part of your overall system preventive maintenance program.

### -ALTERNATE PRETENSIONING METHOD-

- Tighten clevis lock nuts with a torque wrench to a total pretensioning torque as stated the table below.

### REPAIRING THE CABLE CYLINDER

- Dismount the cable cylinder from the machinery.
- Disconnect cables from clevis or load bracket.
- Remove sheaves from both heads. Save retaining rings for reattachment.
- Remove the seal gland retaining ring from each head.
- Remove the tube retaining socket head cap screws from each head.
- Grasp one cable and pull the piston towards one end until exposed.
- Disconnect the cables from each end of the piston.
- Pull the cable assembly back through each head to remove.
- String a new cable assembly through the head in reverse order. Lubricate O-ring found on O.D. of gland. Take care in reseating the integral gland. Do not use sharp instruments, they may damage the cable seal or damage the nylon cable jacket.

- Reinstall the seal gland retaining ring. 11. Replace all seals and gaskets.

- Reconnect the cable assemblies to the piston. **Loctite® (blue)-242 or Permabond #MM-115 must be used on the piston terminal connections.**

- Insert piston back into the tube taking care to gently tuck the U-Cups into the tube with a blunt instrument.

- Reattach the cylinder heads using the socket head cap screws taking care to properly align the heads.

- Remount the sheave assemblies.

- Reconnect the cable assemblies to the clevis or load bracket.

- Test the cable cylinder for function and leaks.

- Reinstall the cable cylinder to the machinery and follow proof-loading and pretensioning instructions.